

Quick Installation Guide for Parallel System



Part 1 Preparation

1.1 System Diagram

Cables marked with majuscule in below system diagram will be introduced in this manual.

- A** EPS connection between Inverter and parallel box (refer to Part 2)
- B** Grid connection between Grid Distribution Box and parallel box (refer to Part 2)
- C** EPS Load connection between EPS load and parallel box (refer to Part 2)
- D** Earth connection between parallel box and external earth bar (refer to Part 2)
- E** Earth connection between parallel box and EPS Load (refer to Part 2)
- F** Communication connection between parallel box and Master Inverter (refer to Part 2)
- G** Communication connection between Inverters (refer to Part 3)
- H** Communication connection between Master Inverter and SOLAX meter (refer to Part 3)

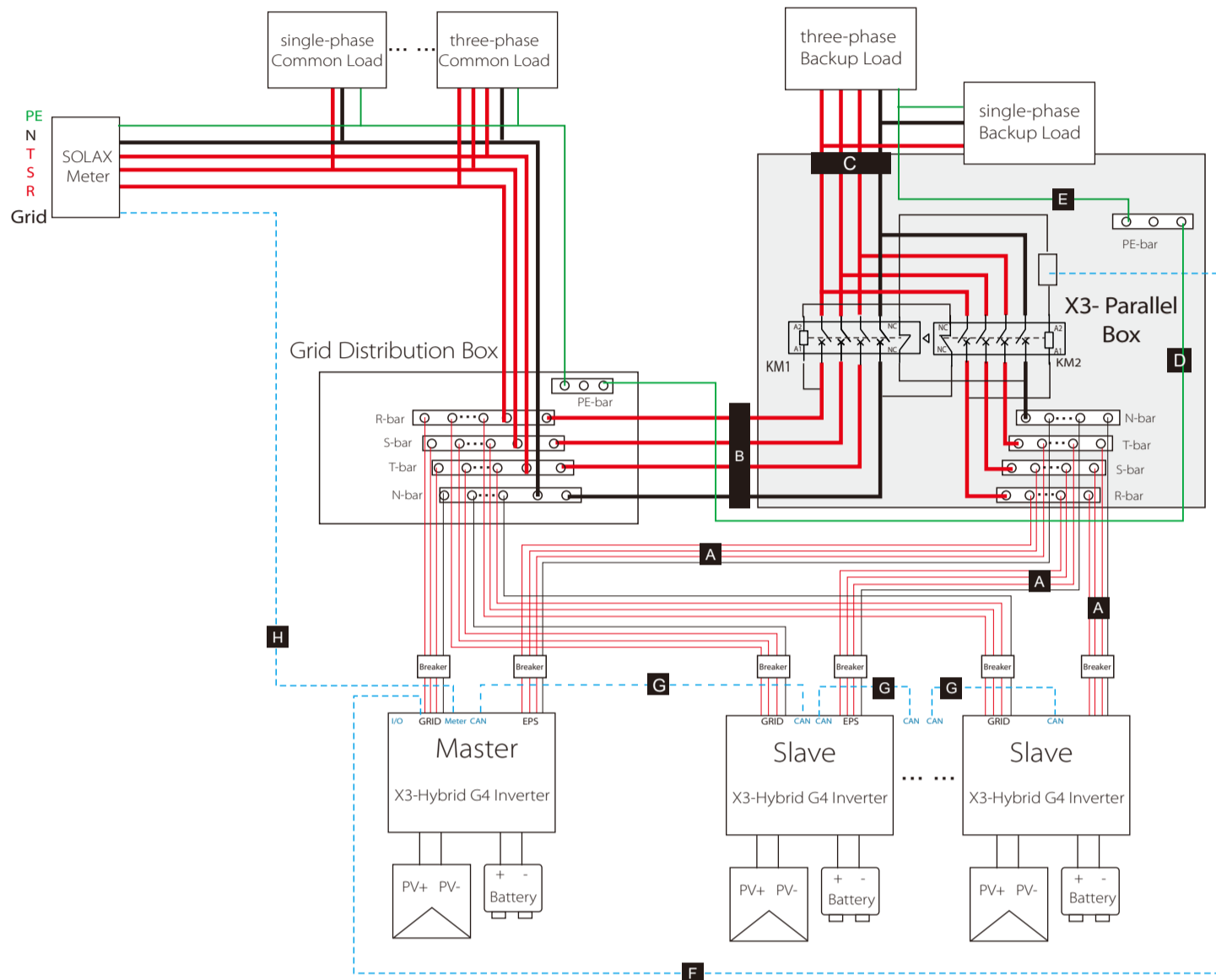

1.2 Packing List

Expansion bolt * 4	Gasket(M8) * 4	Cold-pressed terminal (35-6) * 1, (70-10) * 8	Cold-pressed terminal(S-5) * 44	RJ 45 terminals * 1	Communication terminal (green) * 1 (choose a suitable one when installing)
Board marking paper * 1	Bracket * 1	M4 inner hexagon bolt * 2	Ground terminal (length, 450mm) * 1	Warranty card * 1	Quick Installation Guide * 1

1.3 Cable Preparation

- Press the terminal harness.

Connectors	Application	Connectors	Application	Connectors	Application	Connectors	Application
R/S/T/N EPS Connector X 10 pairs		Grid R/S/T/N/PE Connector X 1 pcs		Load&Grid R/S/T/N Connector X 1 pcs		RJ 45 terminals 1 pcs	
						Switching communication connection X1 pcs	

1.4 Mounting

- Use the attachment bag of control cardboard drill four $\Phi 8$ holes.
- Depth: at least 80mm

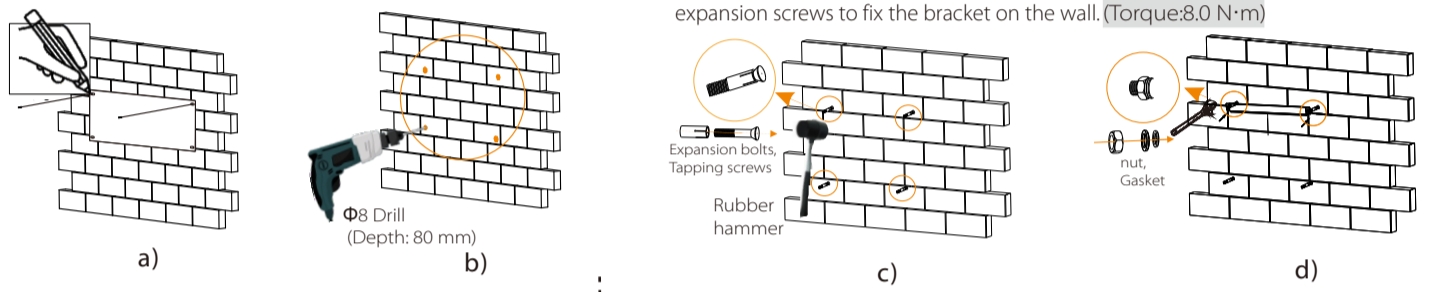

- Hang the box on the bracket on the wall.
- Fix the bottom of the box in the same way of how the bracket is fixed. (Torque: 8.0 N·m)
- The picture on the right shows the back of well-fixed box.

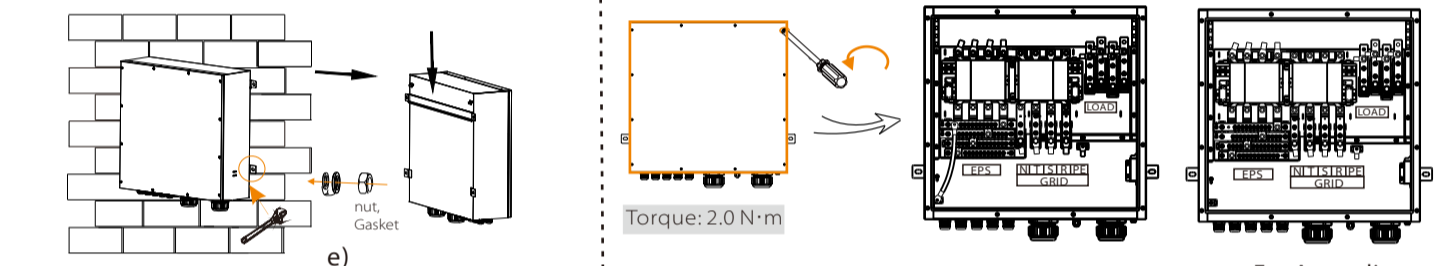

Note: Please refer to the turning radius of the prepared cables about the distance between the bottom of parallel box and the floor.

For Other Areas

For Australia

Part 2 Installation of Parallel BOX

2.1 Connection Overview of Parallel BOX

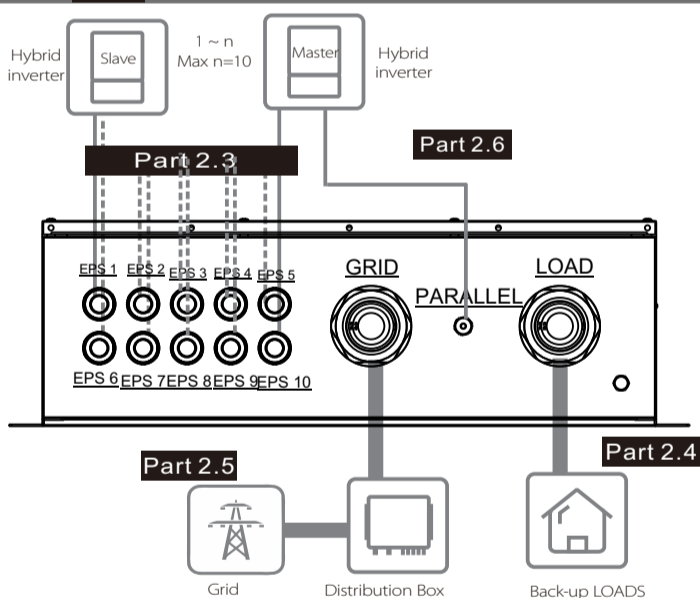

Important Warning!
- Every cable must be connected according to correct line sequence(R-R, S-S, T-T, N-N), otherwise any small misoperation may cause the system running failed.

- 2.3** EPS Connection
- 2.4** Back-up Load Connection
- 2.5** GRID Connection
- 2.6** Communication Connection

2.2 Cable Size Recommended

Note: Soft cables are suggested for ease of installation.

EPS	R-cable, S-cable, T-cable, N-cable	4-6mm ² * 4 PCS for one EPS port
	Outer Diameter of EPS Cable	12.5 -18 mm
	4 cables needed for one EPS port (one inverter) 8 cables needed for two EPS ports (two inverters paralleled) 40 cables needed for ten EPS ports maximummly (Ten inverters paralleled)	
Back-up Load	R-cable, S-cable, T-cable, N-cable	70mm ² * 4 PCS
	Outer Diameter of LOAD Cable	18-44 mm.
Grid	R-cable, S-cable, T-cable, N-cable	70mm ² * 4 PCS
	PE-cable	35mm ² * 1 PCS
	Outer Diameter of GRID Cable	23-56mm
Communication	Communication cable	>0.2mm ² * 2 PCS for one communication port
	Outer Diameter of Communication Cable	6-8 mm

2.3 EPS Connection

Connection of EPS Parallel Box side

Make EPS cables

Remove 10mm insulation from cable ends, and then insert the stripping terminal. Press the terminal head with the blank holder.

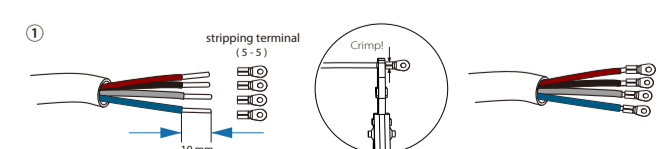

Screw cables

Screw cables through the EPS port on the bottom of the BOX to corresponding EPS ports (R-bar, S-bar, T-bar, N-bar, G-bar) by screwdriver. (refer to picture as right)

Torque: 1.0 N·m

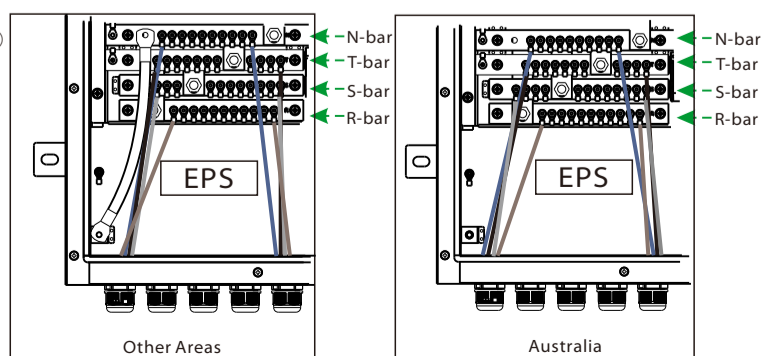

Connection of Inverter side (please refer to Inverter User Manual for details)

Make other side of EPS cables

Remove 10mm insulation from cable ends, then Insert the AC terminal. Press the terminal head with the blank holder.

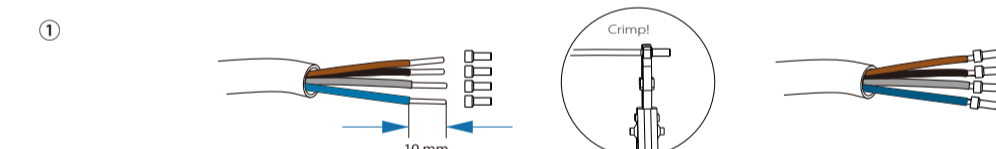

Screw cables

When it is applied to X3-Hybrid G4, wires can be inserted into EPS port through screw cap. And how X3-Hybrid/Fit G2 should be connected can be found from the appendix.

(For specific installation steps, please refer to the EPS port installation chapter of the X3-Hybrid /Fit Quick Installation Guide.)

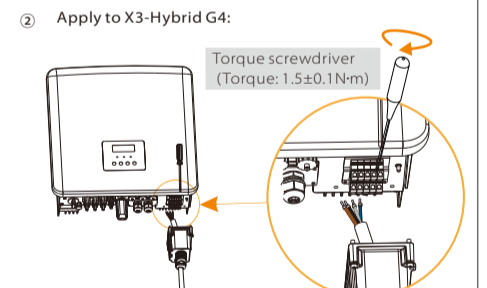

2.4 Back-up Load Connection

Connection of Parallel Box side

Make Load cables

Remove 21 mm insulation from cable ends, and then Insert the stripping terminal. Press the terminal head with the blank holder.

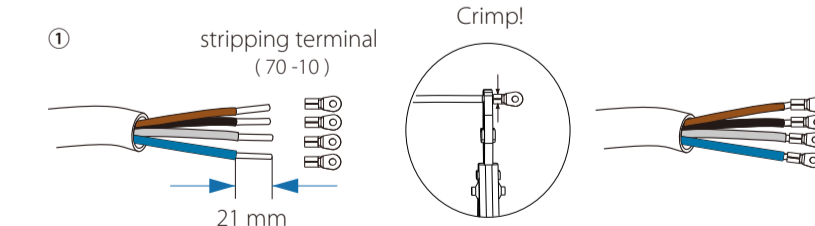

Screw cables

Pass the completed wiring harness through the Load port and follow the corresponding wiring ports (R-bar, S-bar), (T-bar, N-bar) install it and tighten the screws. Torque: 2.0 N·m (refer to picture as right)

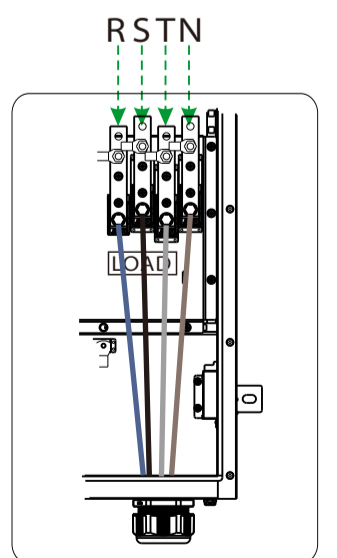
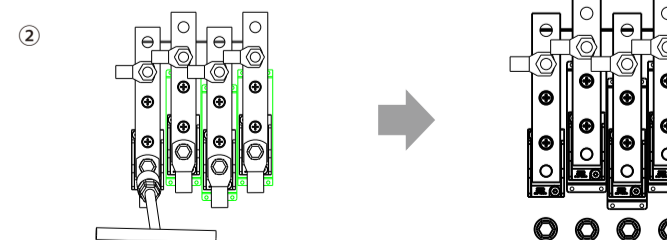

Connection of back-up load side

Selecting appropriate Back-up loads

The requirement shown as below must be satisfied:

- 1: Algebraic apparent power of back-up loads **must be less than** Algebraic apparent power of hybrid system * 0.9
- 2: Algebraic RCD apparent power of RCD back-up loads **must be less than** Algebraic apparent power of hybrid system * 0.6.

Back-up Load connection of loads side should be analyzed and operated depending on specific loads. Here will not be described into details.

Part 2 Installation of Parallel BOX

2.5 GRID Connection

Connection of Parallel Box side

Make Grid cables

Remove 21 mm insulation from the four cable ends and 17 mm insulation from the PE cable end, and then insert the stripping terminal. Press the terminal head with the blank holder.

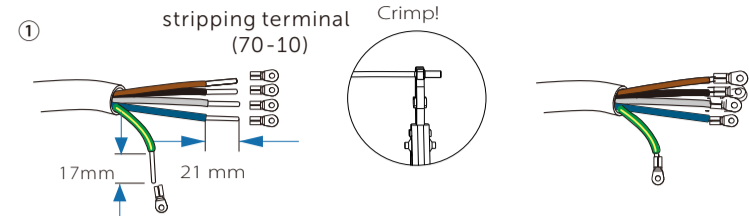

Screw cables

Screw cables through the GRID port on the bottom of the BOX to corresponding Grid ports (R-bar, S-bar, T-bar, N-bar, G-bar) by screwdriver.

Note: Users can connect those terminals according to the corresponding stickers. (please refer to picture as below) Torque: 22.0 N·m

For Other Areas

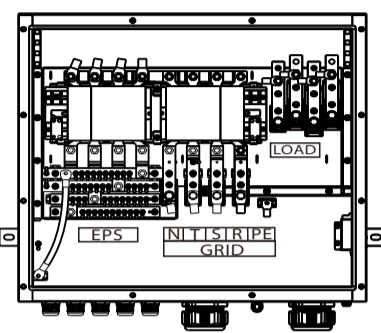

For Australia

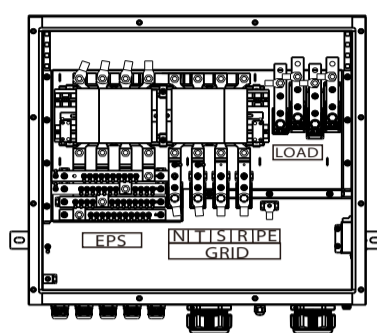

Notice: Grid port connection of grid distribution box side should be analyzed and operated depending on field wiring condition. Here will not be described into details.

2.7 Ground Connection

Step 1: Find a longer ground cable from the attachment.



Step 2: Twist the screw between the ground terminal inside the cabinet and the ground terminal of the chassis, connect them with a ground cable, and tighten the screws.

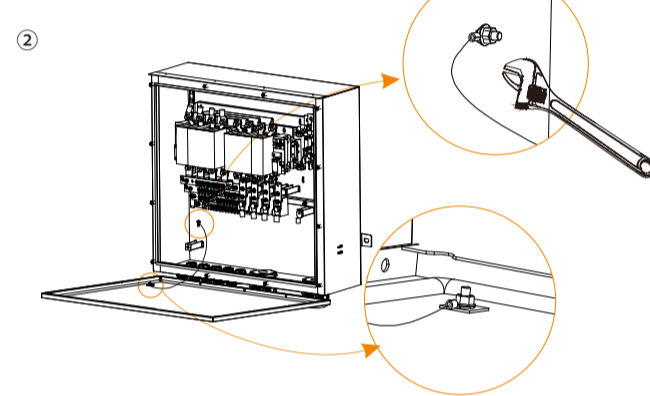

- Finally, install the upper cover of the machine and tighten the screws.

Notice: The ground connection of the box for Australia is taken for an example in picture 2. As the connection method of ground connection of European box is same, please refer to this method.

2.6 Communication Connection

Connection of Parallel Box side

Make communication cables

When users apply X3-HybridG4 inverter, please follow the steps below: Find a common network cable and Remove 4mm insulation from cable ends. Insert the cable into the RJ45 terminal in the accessory kit, and then use a diagonal pliers to tighten the cable and insert it into the corresponding port.

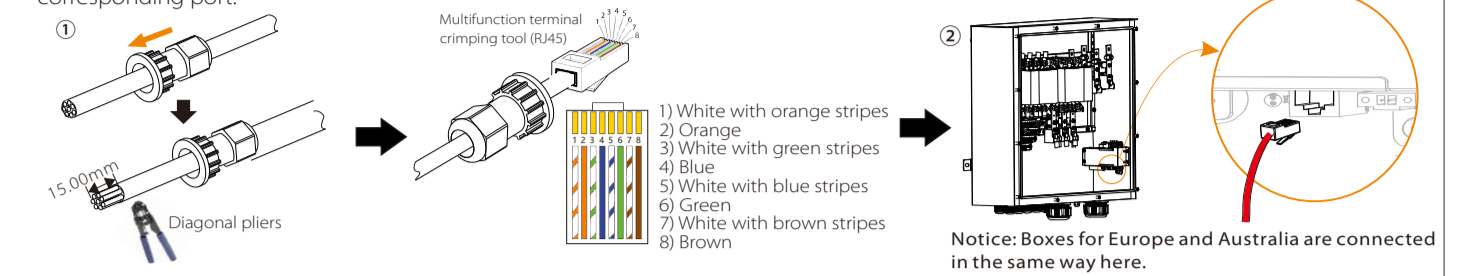

Notice: Boxes for Europe and Australia are connected in the same way here.

Connection of Inverter side (please refer to Inverter User Manual for details)

When users apply X3-Hybrid G4 inverter, please connect as follows:

* Note: It is best to connect the CAN port on the left of "Master" to X3-Parallel Box, and connect the CAN port on the right to "Slave".

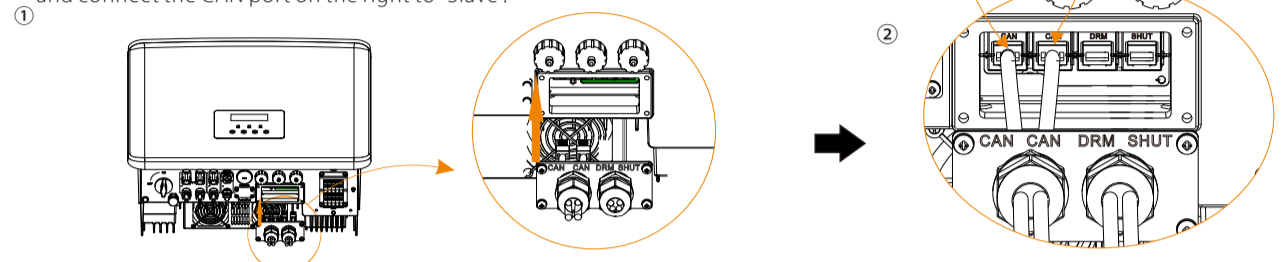

Part 3 Installation of Parallel System

CAN-CAN connection:

Insert one side of CAT7 cable into the first inverter's CAN port and the other side into the next inverter's CAN port.

RS485-Meter connection:

Insert one side of CAT5 cable into the RS485 port of meter, and the other side into the CAN 1 port of the first inverter or the CAN 2 port of the last inverter.

Please note the inverter connected with meter will be the Master Inverter and this Master inverter must be connected with battery.

When users apply X3-Hybrid G4 inverter, please connect as follows:

Note: The installation method of X3-Hybrid/Fit G2 inverter is placed in the attachment.

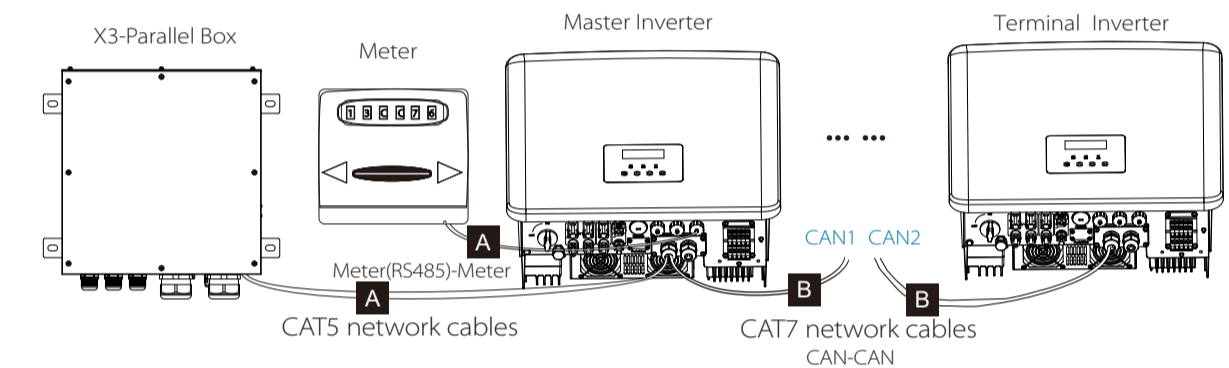

Part 4 LCD Operation

There are three work modes in parallel system, and your acknowledgment of different inverter's work modes will help you understand parallel system better, therefore please read it carefully before operating.

Free mode	Only if no one inverter is set as a "Master", all inverters are in free mode in the system.
Master mode	When one inverter is set as a "Master", this inverter enters master mode. Master mode can be changed to free mode.
Slave mode	Once one inverter is set as a "Master", all other inverters will enter slave mode automatically. slave mode can not be changed from other modes by LCD setting.

"Master Inverter" setting in LCD display

Find the inverter connected with the Solax meter, then enter the setting page of the inverter LCD screen, click on the parallel settings, and select "master control"; then enter the "resistance switch" and set it to "ON"; Finally, find the last slave in the parallel system and enter the setting page of the inverter LCD screen and set the "resistance switch" to "ON".

- If one inverter want to exit from this parallel system, please do the steps as below:
step 1: Disconnect all the network cables on the CAN port.
step 2: Disconnect all power cables (R/S/T/N/PE) connected to X3-Parallel Box.
step 3: Enter setting page and click parallel setting, and choose "Free".

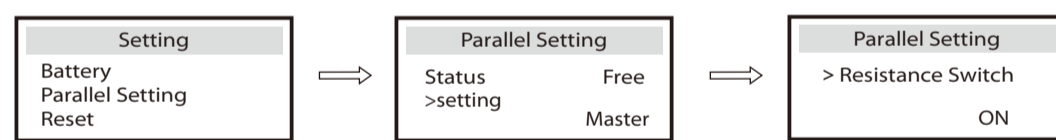

Notes: Once this inverter is set as a "Master", all other inverters will enter "slave mode" automatically.

Main display:

Once inverter enters parallel system, the "today yield" will be replaced by "Inverter Class", and parallel relevant fault has a higher priority than other faults and will be showed firstly on main display.

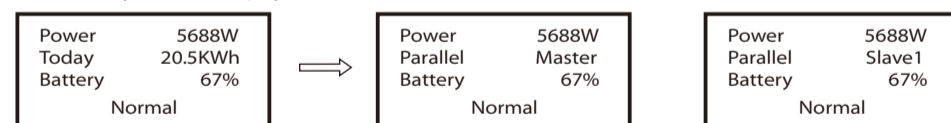

Status display:

User can obtain all the status data from master inverter. System power and individual slave inverter power can be obtain in status display of master inverter.

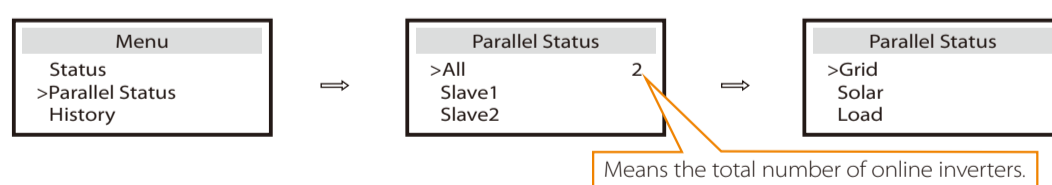

Part 5 Appendix

In this chapter, the difference of the EPS connection, communication connection and installation of parallel system of X3-Hybrid/Fit G2 inverter will be displayed here. If users need to apply X3-Hybrid/Fit G2 inverter, please refer to the following parts.

5.1 EPS Connection

Connection of Inverter side (please refer to Inverter User Manual for details)

Only how to screw wires of X3-Hybrid/Fit G2 inverter is to be written here. Please keep the connection of other parts of the inverter same as that of X3-Hybrid G4.

Screw cables

Insert R(L1),S(L2),T(L3),N wires into corresponding ports of EPS terminal and screw them tightly.

(For specific installation steps, please refer to the EPS port installation chapter of the X3-Hybrid/Fit Quick Installation Guide.)

X3-Hybrid /FitG3 and X3-Hybrid/Fit G2: Torque: 1.2 N·m

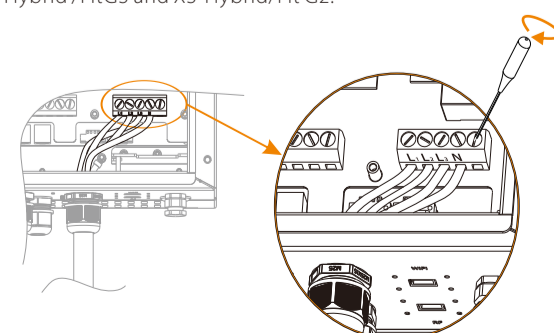

5.3 Installation of Parallel System

When users apply X3-Hybrid/Fit G2 inverter, please connect as follows:

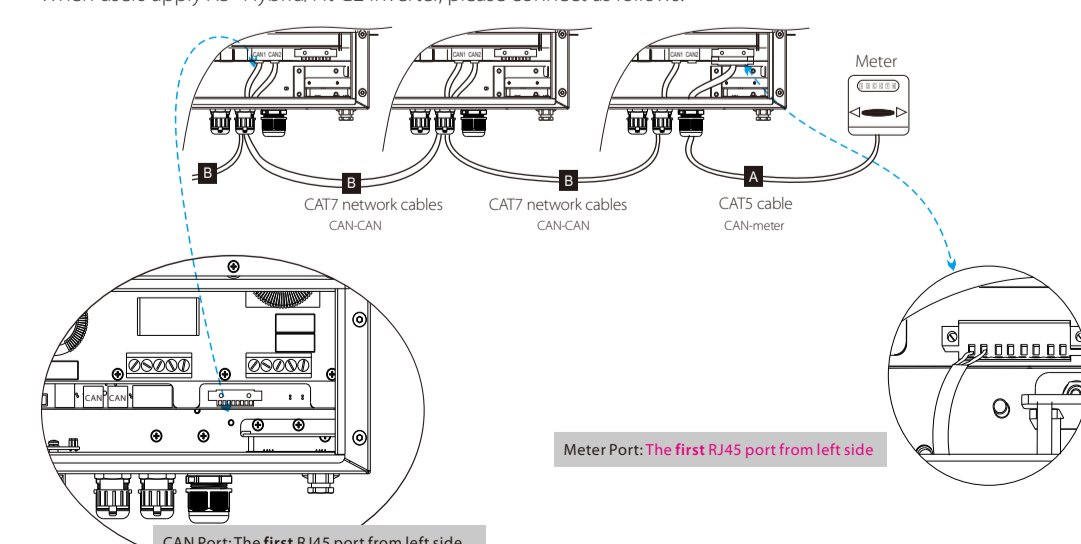

Note: For specific cable operation of these cables, please refer to Inverter User Manual.